

DFLIFT



ELECTRIC PALLET STACKER

EPS-15 Series

HENAN DAFANG HEAVY MACHINE CO., LTD.

 www.dflift.com

 info@dflift.com

 Room 3011, Jingye International, Jinsui Avenue, Xiner Street,
Xinxiang City, Henan Province



EPS-15 Series Electric pallet stacker

Capacity: 1500kg

Lifting Height: 2000/2500/3000mm

Fork Size: 1080*140mm

Fork Width: 550/685mm

Battery Power: Lead acid battery maintenance-free 24/70ah
(optional lithium battery)

Control: Handel / Full electric

 Offset handle, compact body, suitable for narrow aisle.

 Permanent magnet brushless motor.

 Maintenance-free lead-acid battery/optional:
lithium battery.

 Explosion-proof hydraulic unit.

 External intelligent charger.



PARTS DETAILS



Emergency stop switch and indicator light



Voltage, power and working hours display



User-friendly integrated handle, easy to operate



Thick hydraulic cylinder, double chain



Charging interface, external intelligent charger, convenient and safe



High strength steel construction with limit switch, side roller and gantry roller.



Solid PU bearing wheel, more stable and wear-resistant



Integrated driving wheel, smooth operation, accurate control, quick response

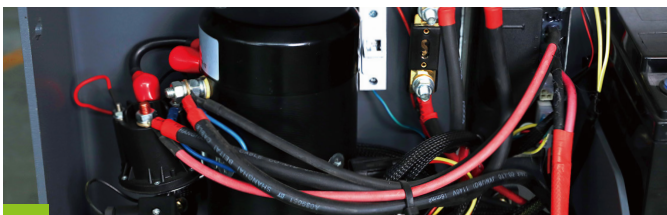

Integrated pump station, low noise, low vibration, high sealing performance



LINE GRAPH

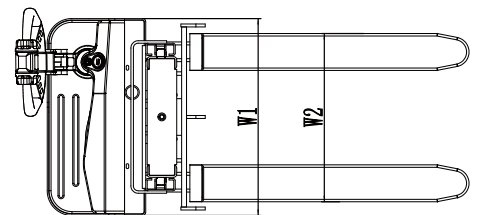
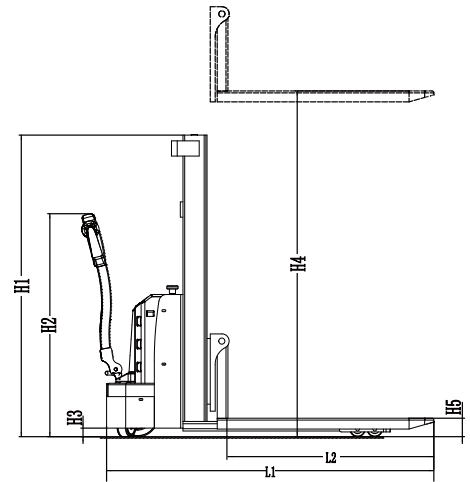

PRODUCT PARAMETERS

FEATURE					
1.1	Model		EPS15-20	EPS15-25	EPS15-30
1.2	Power Type		Maintenance-free lead-acid battery (lithium battery optional)		
1.3	Operation Type		Full electric control		
1.4	Load Capacity	kg	1500	1500	1500
1.5	Load Center	mm	400	400	400
1.6	Lift Height	mm	2000	2500	3000
1.7	Wheelbase	mm	1151	1151	1151
DIMENSION					
2.1	Overall Dimension(L×W)	mm	1730×800	1730×800	1730×800
2.2	Overall Height	mm	1580/2550	2030/3250	2630×3750
2.3	Fork Dimension	mm	1080×140×60	1080×140×60	1080×140×60
2.4	Fork Width Min./Max.	mm	550/685	550/685	550/685
2.5	Min. Ground Clearance	mm	5	5	5
2.6	Turning Radius	mm	1410	1410	1410
2.7	Channel width(1000*1200mm tray)	mm	1000	1000	1000
WEIGHT					
3.1	Self Wight(with battery)	kg	500	540	620
3.2	Battery Weight	kg	52	52	52
WHEEL					
4.1	Wheel Type (Driving / Turning)		Solid PU	Solid PU	Solid PU
4.2	Driving Wheel Sizes	mm	210×70	210×70	210×70
4.3	Auxiliary wheel Sizes	mm	110×55	110×55	110×55
4.4	Loading Wheel Sizes	mm	80×70	80×70	80×70
4.5	Front wheelbase	mm	530	530	530
4.6	Rear wheelbase	mm	503	503	503
4.7	Minimum ground clearance	mm	30	30	30
POWER UNITS AND CONTROLS					
5.1	Rated power of drive motor	kw(60min)	0.8	0.8	0.8
5.2	Lifting motor power rating	kw(60min)	2.2	2.2	2.2
5.3	Battery Dimension	mm	271×174×213	271×174×213	271×174×213
5.4	Battery Voltage/Capacity	V/ah	24/70	24/70	24/70
5.5	Controller		DC	DC	DC
5.6	Working Pressure	mpa	12	12	12
PERFORMANCE PARAMETERS					
6.1	Driving Speed Unladen/Laden	km/h	4/4.5	4/4.5	4/4.5
6.2	Lifting Speed Unladen/Laden	mm/s	45/55	45/55	45/55
6.3	Lowering Speed Unladen/Laden	mm/s	40/55	40/55	40/55
6.4	Rated tractive effort	kN	1.1	1.1	1.1
6.5	Maximum climbing grade capacity	%	5/7	5/7	5/7
6.6	Type of travel brake		Electromagnetic Induction		
6.7	Type of parking brake		Electromagnetic Induction		
OTHERS					
7.1	Type of drive control		Electric	Electric	Electric
7.2	Type of steering		Manual	Manual	Manual
7.3	Noise level	dB	68	68	68
7.4	Waterproof rating		IP54	IP54	IP54



HENAN DAFANG HEAVY MACHINE CO., LTD.

Phone: +86-373 585 9155

web: www.dflift.com

Mobile: +86-173 3731 8355

Email: info@dflift.com

Add: Jingye International, Xinxiang City, Henan Province